EL702, Size M Cabinet NEMA Size 5



Description

The Eagle Size M Cabinet protects electronic components including controllers and other equipment. It features an aluminum enclosure for protection from all forms of outdoor natural elements including rain, sleet, and snow, as well as seepage and splash.

Optional Configurations

- Outward-rotating door handle.
- Double-flanged door frame to provide a better splash shield.
- Continuously welded enclosure for maximum protection from contaminants.
- Unique lock/keying combinations.
- Custom finish per customer requirements.
- Lifting ears.
- Pedestal or pole mount available.



Eagle EL702 Cabinet

Eagle Traffic Control Systems continues our 80+ year history of providing excellence in the ever evolving traffic industry. All of Eagle's products are developed with the highest standards of engineering and manufacturing. Eagle maintains a superior level of integrity in interactions with all of our business partners and customers. We also take tremendous pride in being model corporate citizens.

Eagle Traffic Control Systems is a division of:



EL702, Size M Cabinet NEMA Size 5



EAGLE

Traffic Control Systems

Standard Door Specifications

- Provided with three-point locking mechanism with nylon rollers at the top and bottom.
- 3/4" diameter stainless steel outward turning handle with provisions for padlocking.
- Main door lock - industrial standard pin tumbler lock with #2 key.
- Louvered inlet with filter to prevent dirt from entering with air flow.
- Closed cell PVC door gasket with polyester film to prevent sticking.
- Heavy gauge stainless steel continuous hinge utilizing a 1/4" diameter stainless steel hinge pin for door support, carriage bolted in place for ease of door removal.
- A 2" deep fabricated switch compartment is included with a standard police lock and a stainless steel continuous hinge with a 1/8"-diameter hinge pin riveted in place. Compartment is mounted flush to the door.

Standard Enclosure Specifications

- Completely fabricated from .125"-thick type 5052-H32 mill-finished aluminum utilizing intermittently welded construction, subsequently weatherproofed with silicone sealant.
- Internal attaching components include four (4) adjustable "C" mounting channels (2 per side), and two (2) slotted rails on rear wall for attaching equipment panels.
- The door opening is double-flanged on top to prevent water drops when the door is open. The opening also includes a mount for two door-operated switches.
- Thermoconvection air ventilation system utilized with provisions for mounting fan for forced-air cooling. Exhaust outlet openings are provided under the roof over-hang.
- All internal and external hardware is fabricated from non-corrosive material.
- Two (2) shelves included.
- Automatic door stop to hold main door open at 90°, 120° and 135°.

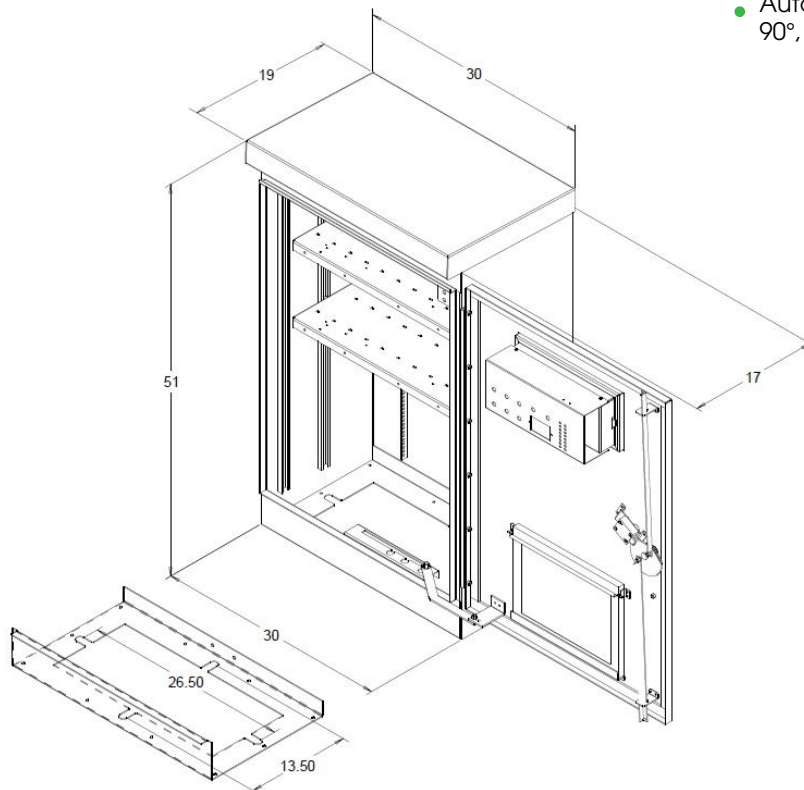

Ordering Information

- EL702- Base Mount
- EL702-S1-Pole Mount

Order 1 (set of 2) anchor bolts, UA243, if required

Order 2 pole mount brackets, UL26, if required